



MLA

Steel, Alu and Pvc Doors&Windows Machinery



M200

Preview Version - 01/2015

Intestatrice semiautomatica per profilati in alluminio e pvc, con morsa pneumatica regolabile $22,5^{\circ} \pm 135^{\circ}$, cambio rapido pneumatico del gruppo frese e avanzamento oleopneumatico.

Semi-automatic end milling machine for aluminium and pvc profiles, with adjustable pneumatic clamp $22,5^{\circ} \pm 135^{\circ}$, pneumatic rapid change of mills group and oil-pneumatic feed.

Machine à abouter semi-automatique pour profilés en aluminium et pvc, avec étai pneumatique réglable $22,5^{\circ} \pm 135^{\circ}$, changement rapide pneumatique du groupe fraises et avancement oléopneumatique.

Halbautomatische Ausklinkfräsmaschine für Aluminium- und Kunststoffprofile, mit pneumatischer ausrichtbarer Spannvorrichtung $22,5^{\circ} \pm 135^{\circ}$, pneumatischem Schnellwechsel des Fräsersatzes und ölpneumatischem Vorschub.

Retestadora semiautomática para perfilados de aluminio y pvc, con mordaza neumática regulable $22,5^{\circ} \pm 135^{\circ}$, cambio rapido neumático del conjunto de fresas y avance oleoneumático.

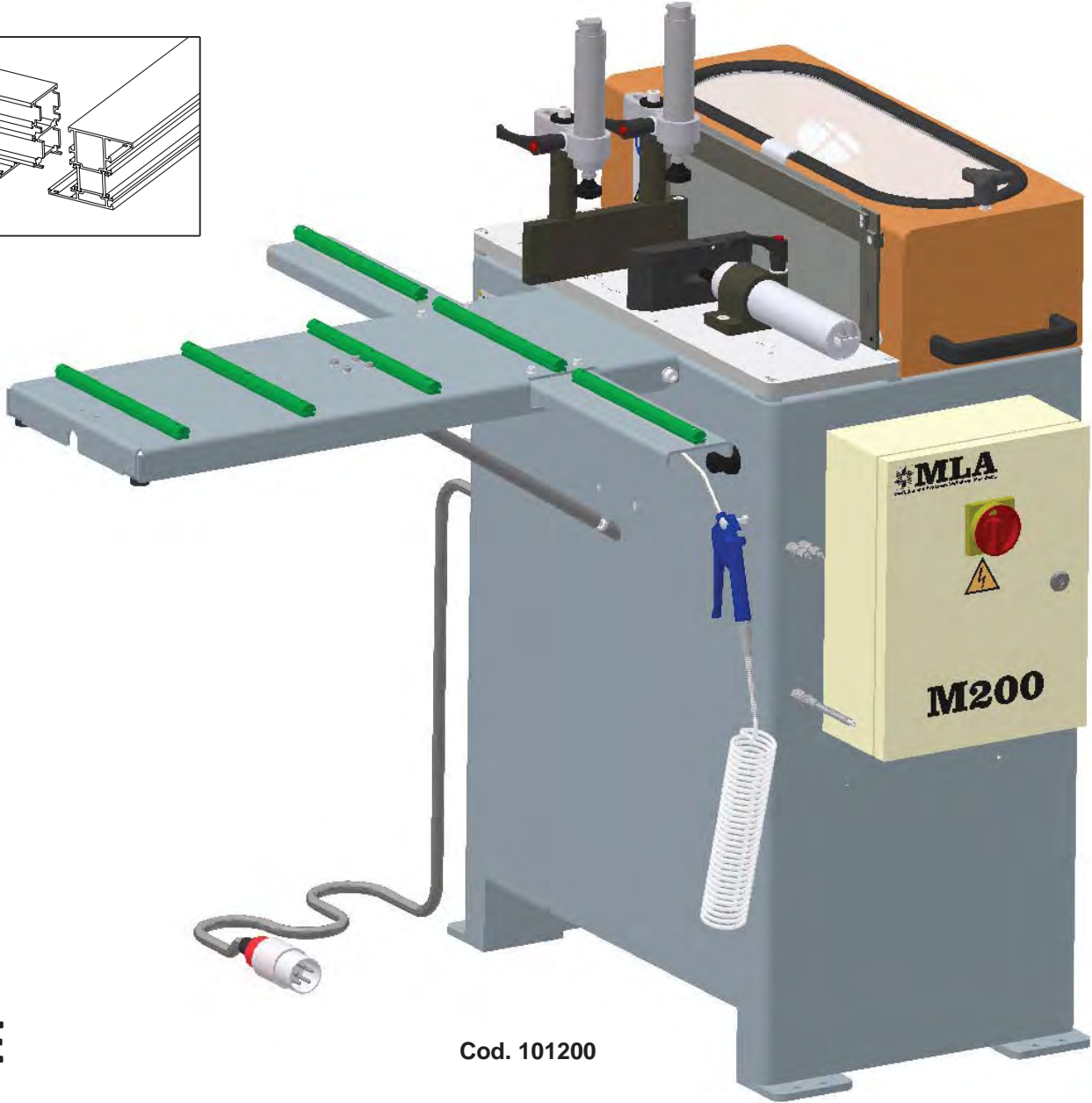
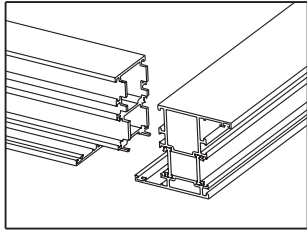

Cod. 101200

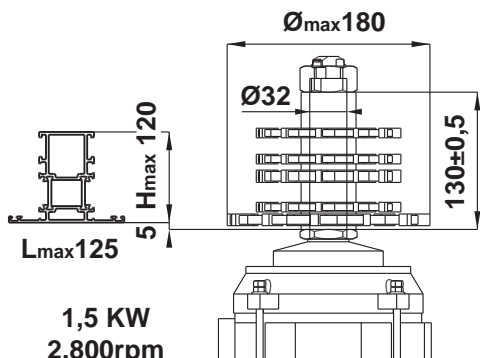

1,5 KW
2.800rpm



3+T+N
400 Volt



6÷8 Bar

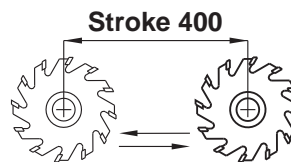

Stroke 400

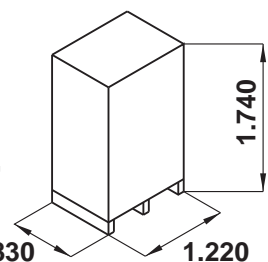

830
1.220
1.740

