



MLA

Steel, Alu and Pvc Doors&Windows Machinery



M300

Version 1.4 - 01/2015

Intestatrice semiautomatica per profilati in alluminio e pvc, con morsa pneumatica regolabile 22,5÷135°, cambio rapido pneumatico del gruppo frese e avanzamento oleopneumatico su guide lineari.

Semi-automatic end milling machine for aluminium and pvc profiles, with adjustable pneumatic clamp 22,5÷135°, pneumatic rapid change of mills group and oil-pneumatic feed on linear guides.

Machine à abouter semi-automatique pour profilés en aluminium et pvc, avec étai pneumatique réglable 22,5÷135°, changement rapide pneumatique du groupe fraises et avancement oléopneumatique sur guidages linéaires.

Halbautomatische Ausklinkfräsmaschine für Alu- und Kunststoff Profile, mit pneumatischer ausrichtbarer Spannvorrichtung 22,5÷135°, pneumatischem Schnellwechselsystem des Fräsesatzes und hydropneumatischem Vorschub auf Linearführungen.

Retestadora semiautomática para perfilados de aluminio y pvc, con mordaza neumática regulable 22,5÷135°, cambio rápido neumático del conjunto de fresas y avance oleoneumático en guías con patines.

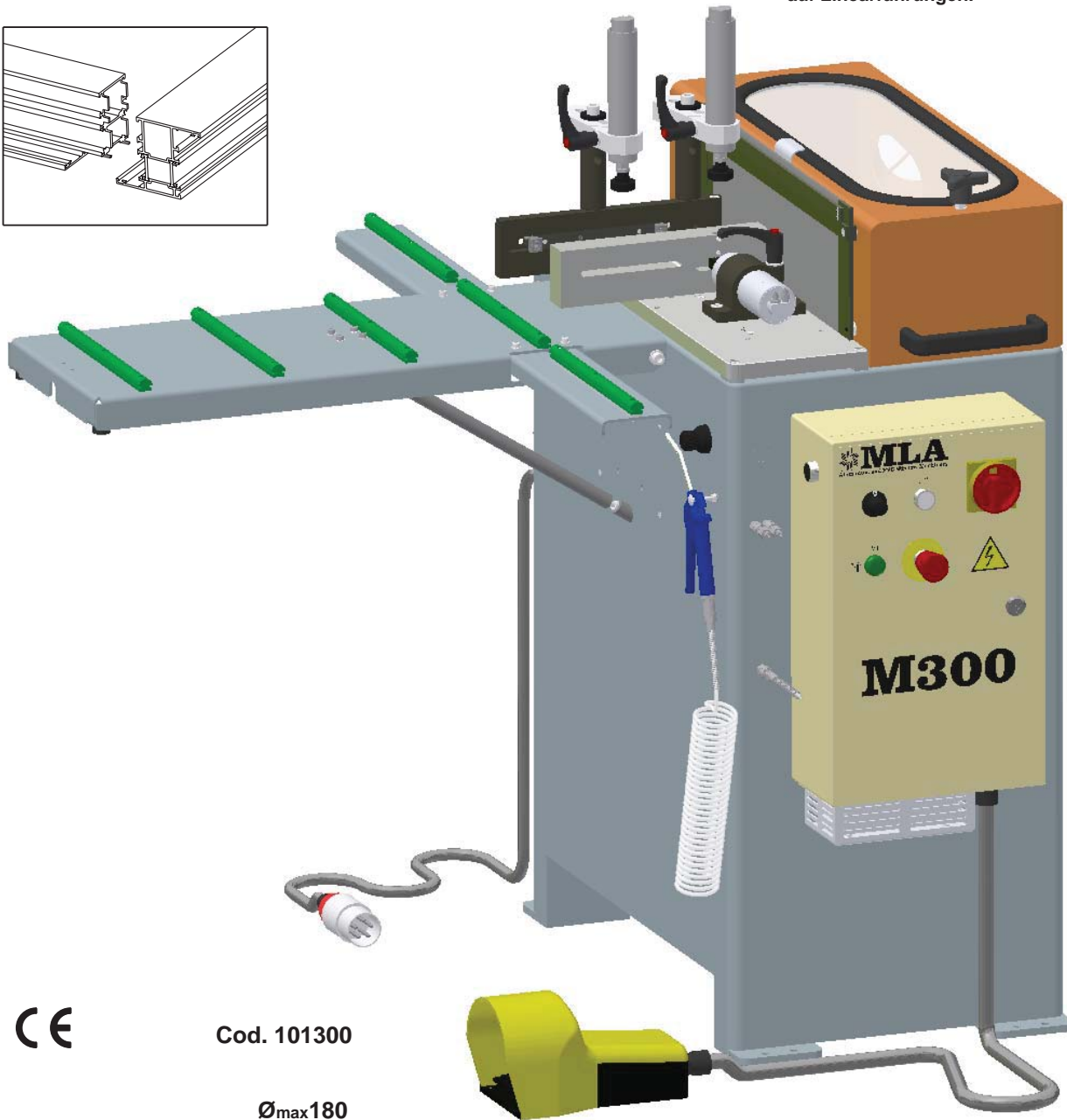
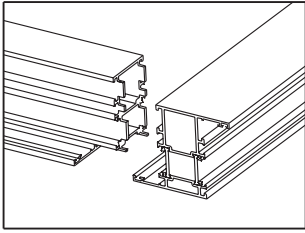

Cod. 101300

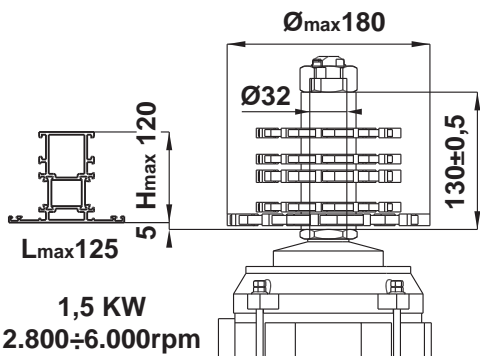

3+T+N
400 Volt



6÷8 Bar

