

# univer

## ML139 ML140/141/142

FRESATRICE PER SCARICO CONDENZA  
WATER SLOT MACHINES  
WASSERSCHLITZFRÄSEN  
FRAISEUSES POUR RAINURES DE DRAINAGE

### COMPONENTI IN DOTAZIONE

Base in lamiera.  
1 Morsa pneumatica orizzontale.  
1 Pinza elastica, diametro 8 mm (una per ogni unità).  
1 Fresino, diametro tagliente 5 mm, diametro codolo 8mm (uno per ogni unità).  
2 Battenti interni a molla.  
4 Battenti esterni.

### OPTIONAL

Battente laterale 1300 mm.destro e sinistro.  
Battente laterale 2000 mm.destro e sinistro.

### MITGELIEFERTE KOMPONENTEN

Untergestell aus Blech.  
1 Stck. horizontaler Pneumatik-Schraubstock.  
1 Stck. Federgreifer, Durchmesser 8 mm (1 Stck. pro Einheit).  
1 Stck. Schneidfräser, Durchmesser 5 mm, Schaftdurchmesser 8 mm (1 Stck. pro Einheit).  
2 Stck. Feder-Innenanschläge.  
4 Stck. Außenanschläge.

### OPTIONEN

Seitenanschlag 1300 mm rechts und links.  
Seitenanschlag 2000 mm rechts und links.

### COMPONENTS SUPPLIED

Steel machine base.  
1 Horizontal manual clamping kit.  
1 Spring collet, diameter 8 mm (one for each unit).  
1 Cutter, cutting diameter 5 mm, shaft diameter 8 mm (one for each unit).  
2 Internal spring stops.  
4 External double stops.

### OPTIONALS







Side length stop 1300 mm right and left.  
Side length stop 2000 mm right and left.

### COMPOSANTS EN DOTATION

Socle en tôle.  
1 Vérin de serrage pneumatique horizontal.  
1 Pince élastique diam. 8 mm (une pour chaque unité).  
1 Fraise coupante diam. 5 mm, queue 8 mm (une pour chaque unité).  
2 Butées internes à ressort.  
4 Butées externes.

### EN OPTION

Butée latérale 1300 mm à droite et à gauche.  
Butée latérale 2000 mm à droite et à gauche.

TYPE								P.V.C.	ALUM.	WOOD
ML 139	0,1 Kw	380 Volt	16000/min	d 5 mm.	a 90 - b 140 mm.	a 480 - b 1540 - c 830 mm	92 Kg	●	○	○
ML142	0,1 Kw x 3	380 Volt	16000/min	d) 5 mm.	a 90 - b 140 mm.	a 550 - b 1540 - c 980 mm.	102 Kg	●	○	○
ML141	0,1 Kw x 2	380 Volt	16000/min	d) 5 mm.	a 90 - b 140 mm.	a 550 - b 1540 - c 980 mm.	90 Kg	●	○	○
ML140	0,1 Kw x 2	380 Volt	16000/min	d) 5 mm.	a 90 - b 140 mm.	a 550 - b 1540 - c 980 mm.	90 Kg	●	○	○

La ditta costruttrice si riserva il diritto di modificare i dati qui sopra riportati senza nessun preavviso. / The manufacturer reserves the rights to change the above mentioned informations without.  
Der Hersteller hat das Recht, die obengenannten Daten zu ändern, ohne Voranzeige geben. / L'usine se réserve le droit de changer les informations mentionnées sans aucun avis.

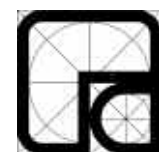

**PERTICI** S.P.A.

VIA DELLE CITTÀ, 41/43 - 50052 CERTALDO (FI) ITALY  
Tel. ++39 (0)571 651204 - Fax ++39 (0)571 652991  
e-mail: pertici@pertici.it - http://www.pertici.it

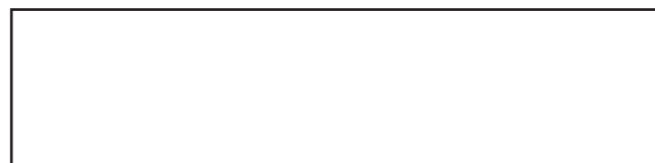

# PERTICI



DIRETTIVA  
EUROPEA  
MACCHINE  
98/37



## univer ML139

## ML140/141/142

FRESATRICE PER SCARICO CONDENZA  
WATER SLOT MACHINES  
WASSERSCHLITZFRÄSEN  
FRAISEUSES POUR RAINURES DE DRAINAGE

univer ML/139

PERTICI CERTALDO

univer ML/142



**ML140**

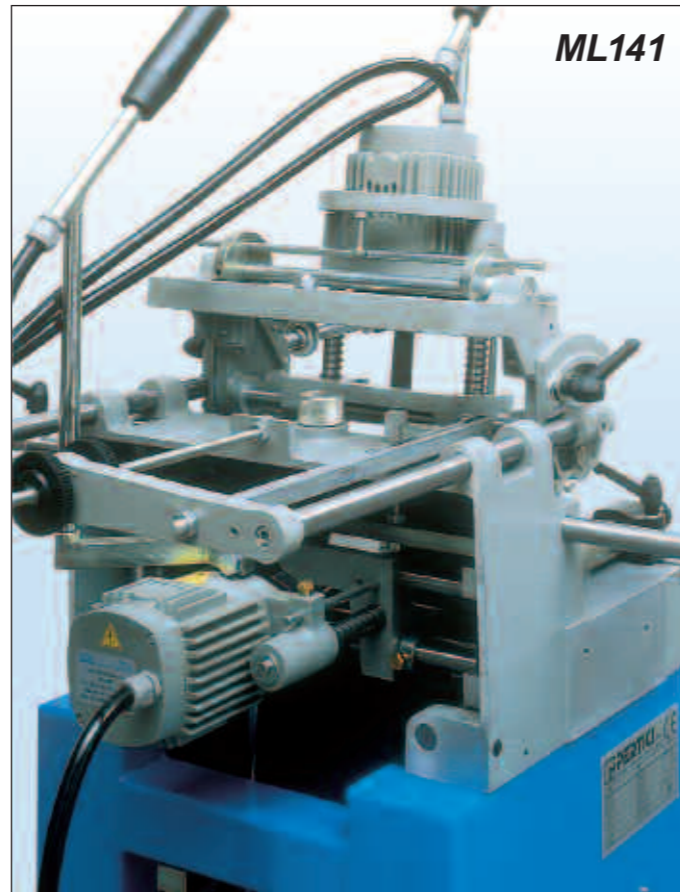

**ML141**

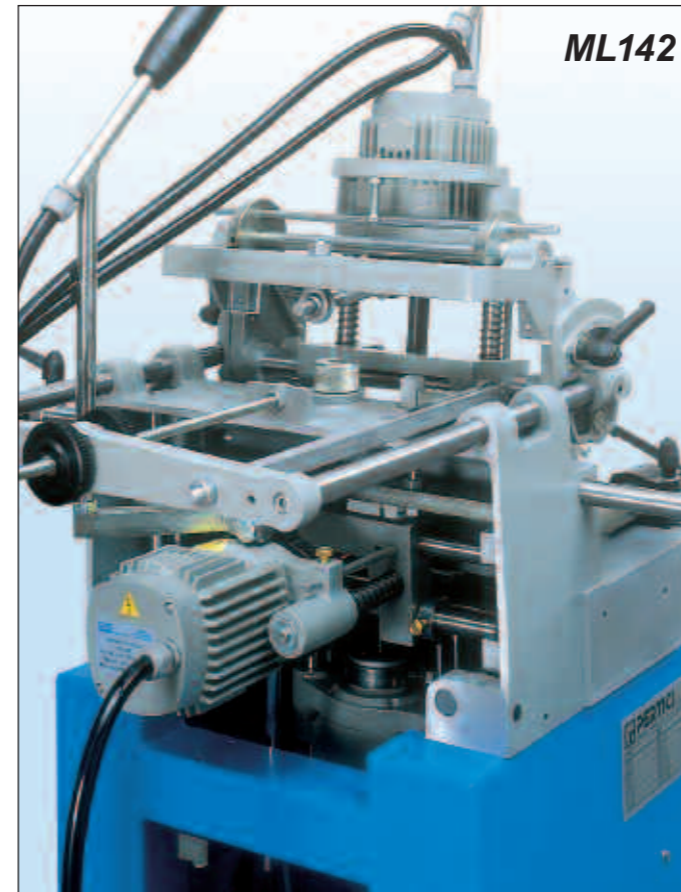

**ML142**



**ML139**

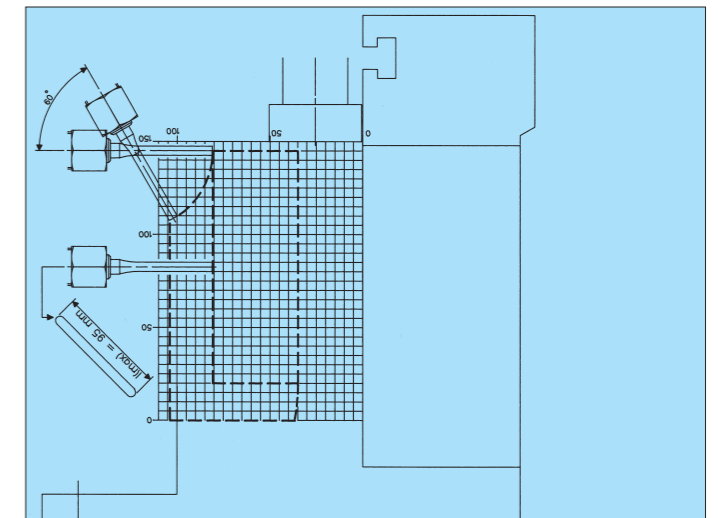
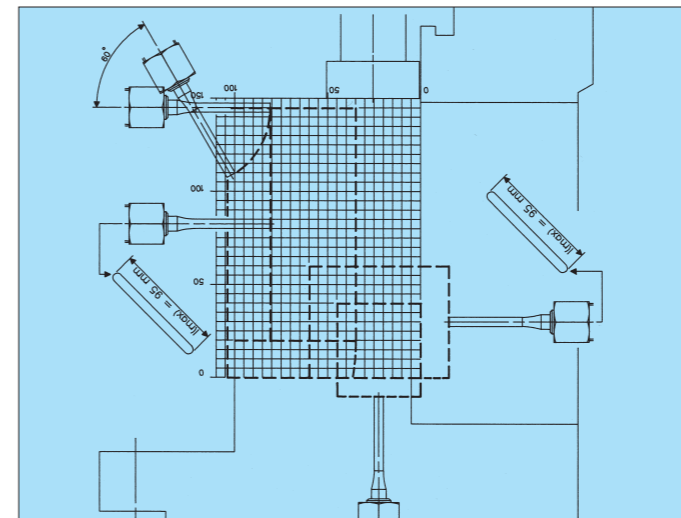
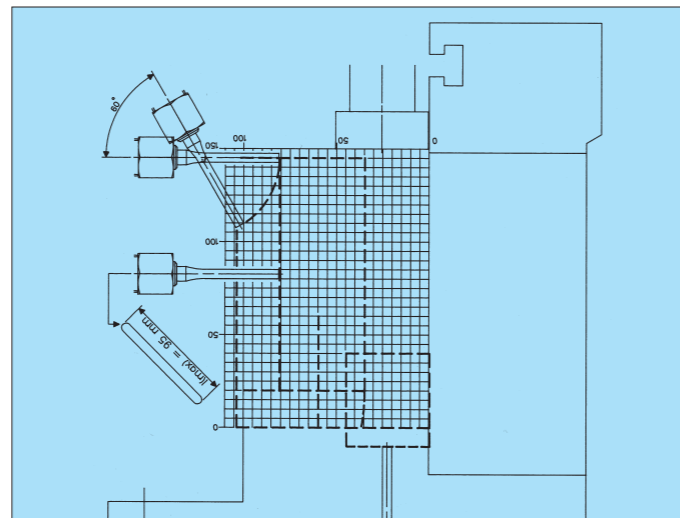
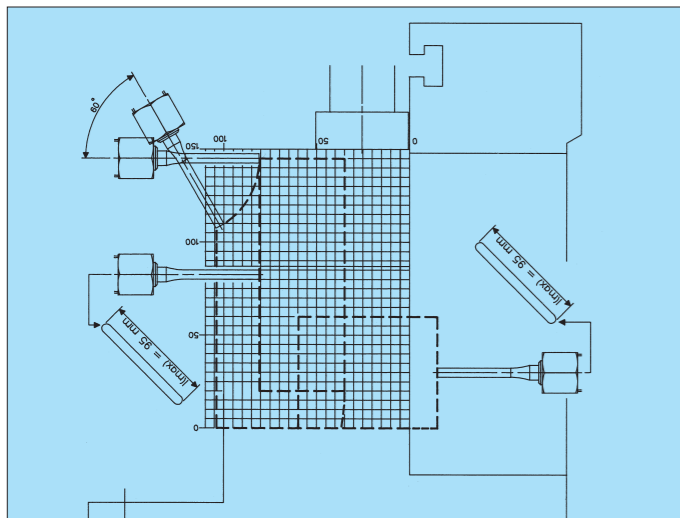

Queste fresatrici sono particolarmente idonee per la lavorazione dei profilati in PVC. Dotate di unità di lavoro indipendenti fra loro consentono la fresatura libera del profilo in senso longitudinale. E' possibile così ottenere asole per lo scarico della condensa o per l'evacuazione dell'acqua.

Il modello ML142 è dotato di tre unità di lavoro, una obliqua inclinabile fino a 60 gradi, una orizzontale ed una verticale.

Il modello ML141 dispone di due unità, una obliqua inclinabile a 60 gradi e una orizzontale.

Il modello ML140 è dotato di due unità, una obliqua inclinabile fino a 60 gradi ed una verticale.

These machines are ideal for the machining of PVC profiles. They have independent routing units for the free lengthwise routing of the profile, and can be used for cutting slots for condensation or water drainage.

The ML 142 has three routing units, one oblique unit tiltable up to 60 degrees, one horizontal unit and one vertical one.

The ML 141 has two units, one oblique unit tiltable up to 60 degrees and one horizontal unit.

The ML 140 has two units, one oblique unit tiltable up to 60 degrees and one vertical unit.

Diese Fräsmaschinen sind insbesondere für die Bearbeitung von PVC-Profilen ausgelegt. Durch die Ausrüstung mit voneinander unabhängigen Arbeitseinheiten können vorlagenfreie Profil-Fräsarbeiten in Längsrichtung zum Erhalt von Längsschlitz für den Kondensat- bzw. Wasserablaß ausgeführt werden.

Modell ML 142 ist mit 3 Arbeitseinheiten in geneigter, bis zu 60° schwenkbarer, horizontaler und vertikaler Ausführung, Modell ML 141 mit 2 Arbeitseinheiten in geneigter, bis zu 60° schwenkbarer und horizontaler Ausführung und Modell ML 140 mit 2 Arbeitseinheiten in geneigter, bis zu 60° schwenkbarer und vertikaler Ausführung ausgestattet.

Ces fraiseuses sont particulièrement adaptées au fraisage des profils en PVC. Elles sont dotées d'unités de fraisage indépendantes qui permettent le fraisage libre du profil dans le sens longitudinal. Cela permet d'obtenir des rainures de drainage ou d'évacuation de l'eau.

Le modèle ML142 est doté de trois unités de fraisage: une oblique inclinable jusqu'à 60 degrés, une horizontale et une verticale.

Le modèle ML141 est doté de deux unités de fraisage: une oblique inclinable jusqu'à 60 degrés et une horizontale.

Le modèle ML140 est doté de deux unités de fraisage: une oblique inclinable jusqu'à 60 degrés et une verticale.