

BAIHA

Corner assembly machine (crimper)

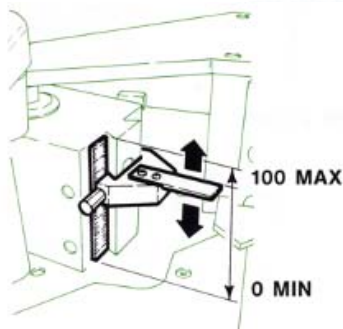

- Possibility of more than one crimping points by height depending on the profile chamber
- Independent adjustment of the two blade units with decimal number readout showing their position
- Fold-away profile fence
- No adjustment required when profile section being machined is changed
- Simultaneous mechanical blades feed by means of a cog wheel system
- Blades stroke 16 mm
- The same blades thrust force over the whole stroke
- Total dimensions: 880 x 850 x 1200 h mm

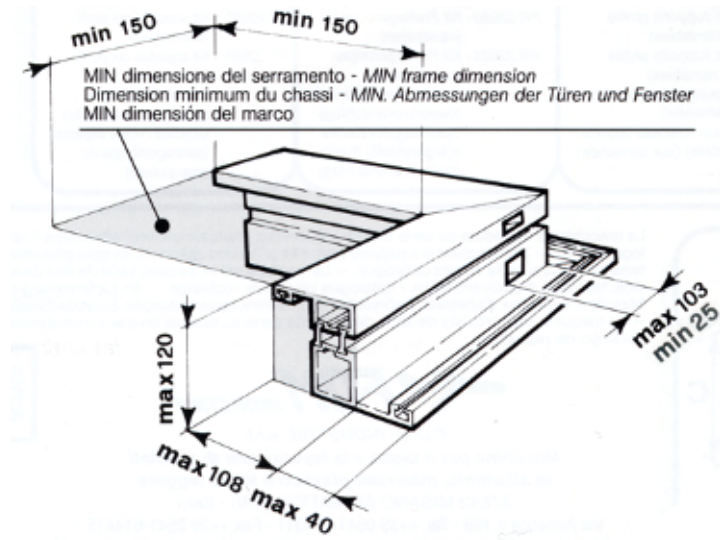

Maximum height of blades

Blades and crimping point positions independently adjustable using decimal numbers readout

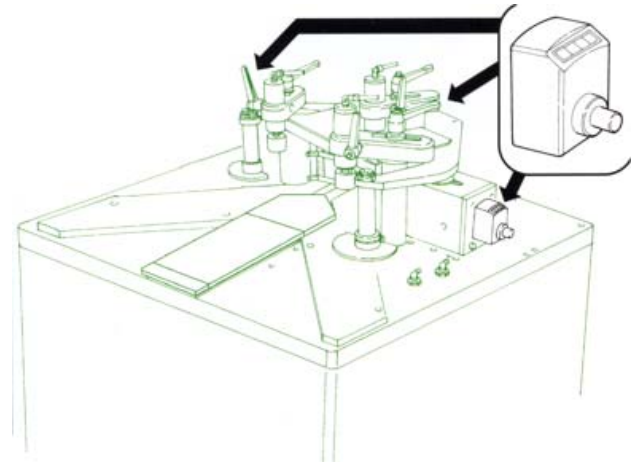

OPTIONALS:

- Additional right tool-holder
- Additional left tool-holder
- Additional tool 2 mm thickness
- Additional tool 5 mm thickness
- Special tool
- Special profile clamping block (counterprofile)
- Swinging profile support kit
- Extendable profile support kit
- Carton packing
- Crate packing